

Zawias 165° hydrauliczny HCKT
 Hydraulic hinge 165° HCKT
 Гидравлическая петля 165° HCKT



ZASTOSOWANIE / APPLICATION / ПРИМЕНЕНИЕ



PARAMETRY / CHARACTERISTICS / ХАРАКТЕРИСТИКИ



OPCJE ZESTAWU / SET OPTIONS / КОМПЛЕКТАЦИЯ



PAKOWANIE / PACKING / УПАКОВКА



SKŁAD ZESTAWU / SET INCLUDES / КОМПЛЕКТАЦИЯ



ZAWIAS O SZEROKIM KĄCIE OTWARCIA 165°
 WIDE ANGLE HINGE 165°
 ПЕТЛЯ С ШИРОКИМ УГЛОМ ОТКРЫВАНИЯ 165°

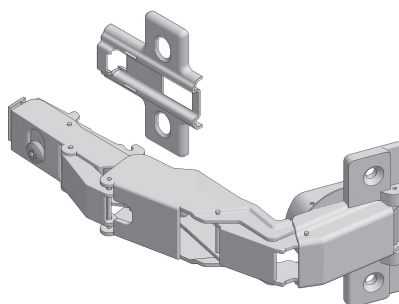

ZM-HCKT165BE	—	—
ZM-HCKT165ZE	—	x 2

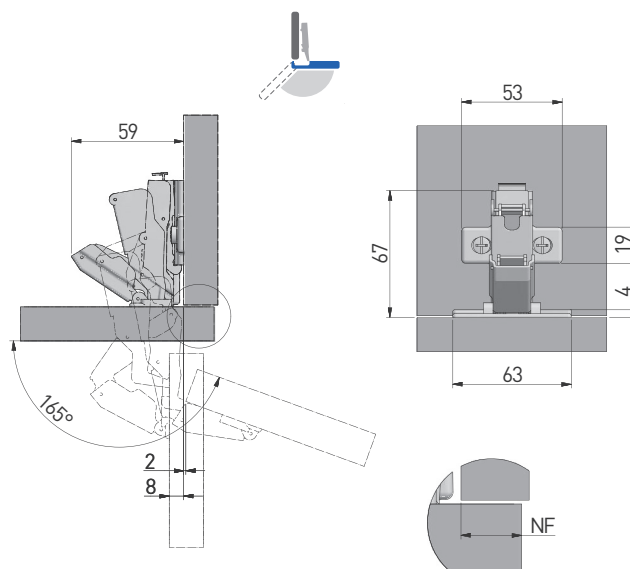

MONTAŻ / MOUNTING / МОНТАЖ

montaż prowadnika w korpusie
mounting plate installation
присадка под ответную планку

montaż puszki we froncie
hinge cup installation
присадка под чашку петли

*		
	ø 2	ø 5

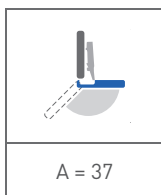
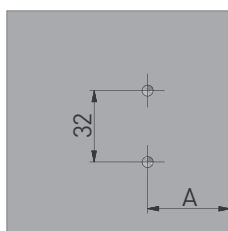
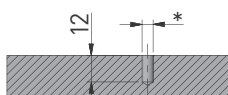

A = odległość prowadnika od krawędzi (mm)
gap between mounting plate
and the cabinet edge (mm)
расстояние от ответной планки
до края (мм)

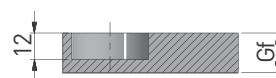

Gf = min. 16 mm
- max. 18 mm

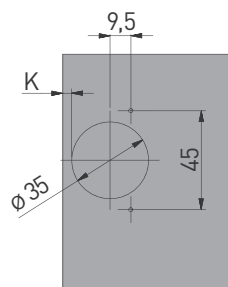

	NF	13	14	15	16	17
H = 0	K			3	4	5

NF = natożenie frontu (mm)
front overlay (mm)
наложение фасада (мм)

K = odległość puszki od krawędzi (mm)
gap between hinge cup and cabinet edge (mm)
расстояние от чашки петли до края (мм)

H = wysokość prowadnika
mounting plate height
высота ответной
планки

Gf = grubość frontu
front thickness
толщина фасада

REGULACJA / ADJUSTMENT / РЕГУЛИРОВКА



± 2 mm



± 2 mm



± 2 mm